

General data sheet

Oil Nozzles Types EH and ES

For specific information on this product, please contact Danfoss Burner Components

Identification

The nozzle is marked with the following information:



OFTEC-specification

1.80 Specified capacity (kg/h)

OFTEC specification point 800 kPa (8 bar), 1.65 cSt., 790 kg/m³
Capacity tolerance: ± 5%

OK OFTEC Kerosene certification

Serial number for internal use

0.60 Reference capacity (USgal/h)

Reference specification point: 700 kPa (7 bar), 3.4 cSt., 820 kg/m³

60° ES Spray angle & pattern (EH = Hollow) (ES = Solid)

Oil nozzles type EH and ES are designed for domestic high-pressure oil burners operating with kerosene. They are available with 2 different spray angles and sizes from 0.4 to 1.10 USgal/h.

The nozzles are equipped with sintered bronze filters.

Our existing oil nozzles e.g. 60°S and 80°H can directly be replaced by our new 60°ES – 80°EH.

Application and Features

- Kerosene
- OFTEC certification (OFS E100)
- 100% test of capacity and performance

Design

Sizes 0.40-0.60 USgal/h with O-ring sealing

- A Nozzle housing
- C Nozzle cone
- D Orifice disc
- H Filter
- S O-ring holder

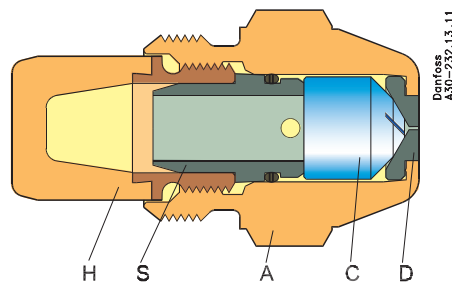

Sizes 0.65-1.10 USgal/h with bottom screw

- B Bottom screw

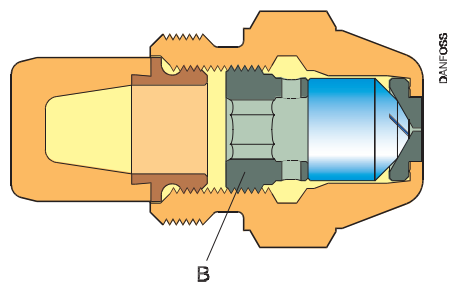

Developed – designed – tested for kerosene application

The kerosene nozzle series meets the requirements of the OFTEC kerosene nozzle standard OFS E100

Spray angles

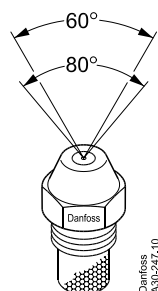

Spray patterns

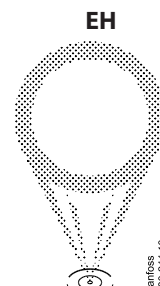

Hollow

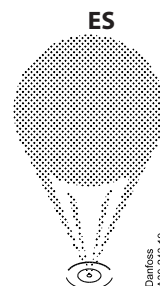

Solid

Technical Data

Filters

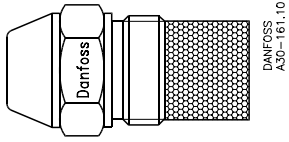

Capacity 0.40-0.85 USgal/h:
45 µm sintered bronze

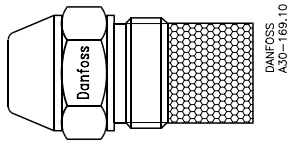

Capacity 1.00-1.10 USgal/h:
75 µm sintered bronze

Tightening torques

Recommended tightening torque	15 to 20 Nm (1.5 to 2.0 kpm)
Max. tightening torque	25 Nm (2.5 kpm)

Oil Nozzles Types EH and ES

Reference capacity USgal/h	Spray angles/patterns				Specified capacity kg/h
	60°		80°		
0.40		ES	EH	ES	1.20
0.45	EH	ES	EH	ES	1.35
0.50	EH	ES	EH	ES	1.50
0.55	EH	ES	EH	ES	1.65
0.60	EH	ES	EH	ES	1.80
0.65	EH	ES	EH	ES	1.95
0.75	EH	ES	EH	ES	2.25
0.85	EH	ES	EH	ES	2.55
1.00	EH	ES	EH	ES	3.00
1.10	EH	ES	EH	ES	3.30

Dimensions

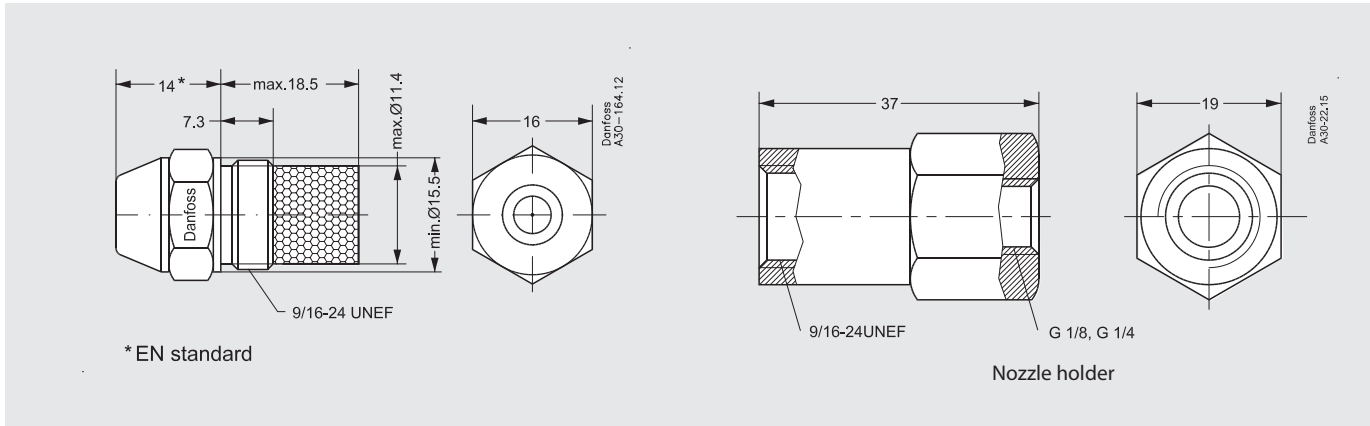

Additional documentation on burner components is available on <http://heating.danfoss.com/> or <https://store.danfoss.com/>

Danfoss A/S

Heating Segment • heating.danfoss.com • +45 7488 2222 • E-Mail: heating@danfoss.com

Danfoss can accept no responsibility for possible errors in catalogues, brochures and other printed material. Danfoss reserves the right to alter its products without notice. This also applies to products already on order provided that such alterations can be made without consequential changes being necessary in specifications already agreed. All trademarks in this material are property of the respective companies. Danfoss and all Danfoss logotypes are trademarks of Danfoss A/S. All rights reserved.