

# Jefferson®



**2.4HP Petrol Cement Mixer**  
JEFCEMPETBLK

**User Manual**  
v.1.1





**Contents:**

General Safety	<b>4</b>
Unpacking & Assembly	<b>5</b>
Basic Operation	<b>5</b>
Specifications	<b>6</b>
Maintenance & Storage	<b>6</b>
Parts List & Diagram	<b>7</b>
<hr/>	
Limited Warranty Statement	<b>8</b>
Declaration of Conformity	<b>11</b>

**Important:** This manual is an essential part of this Jefferson product and should be kept safe with the product for future reference. This manual outlines the purpose for which the product has been designed and contains important information to ensure its correct and safe use. It is essential that you read and understand the information in this manual before operating this equipment.

## 1. General Safety

*This equipment should only be operated by qualified and responsible individuals who have read and understood the information and guidelines described in this document. In particular, the following safety instructions should be followed to reduce the risk of injury to the operator and members of the public.*

- 1.** Familiarise yourself with this equipment and its operation before use - **read this user manual carefully before use.** Save for future reference.
- 2.** This appliance is for outdoor use only. Ensure that all bystanders are kept at a safe distance and that animals and children are kept from the work area.
- 3.** Never use this equipment if any part or accessory is damaged or malfunctioning.
- 4.** Always shut the equipment off completely when not in use and if left unattended.
- 5.** Ensure that the equipment is completely shutdown and disconnected from the mains before carrying out any servicing or repairs.
- 6.** Only Jefferson approved engineers should carry out repairs and maintenance on this equipment. Only use Jefferson-approved replacement parts to repair this equipment. Never modify the equipment in anyway. Ensure that the equipment is kept in good working order and cleaned and serviced regularly. Check the external nuts and fixings regularly to ensure that they have not loosened from vibration during use.
- 7.** Ensure that the electrical cable is fully protected and there is no danger of damage for equipment or materials. Always inspect the cable before use and replace if any damage is apparent.
- 8.** Do not wear jewellery or loose clothing that could be snagged by the rotating drum.
- 9.** Keep your hands clear of the rotating drum at all times. Never put your hands inside of the drum when the machine is running.
- 10.** Ensure that the guards are always used.
- 11.** This equipment is heavy and requires two people to lift and assemble.
- 12.** Ensure that the equipment is operated from a stable even surface.
- 14.** Do not load the drum when the machine is switched off. Always ensure that the drum is rotating before gradually adding the mix. This will help to preserve the motor and gearbox.
- 15.** Do not allow water to come into contact with the motor or electrical components.
- 16.** Do not operate under the influence of alcohol or drugs.
- 17.** Keep the drum free from debris and mortar build up (clean after every use).
- 18.** Keep all moving parts (wheel axles, swivel brackets etc.) lightly greased.
- 19.** Petrol engines can become hot in use, do not refuel or touch hot engine parts until they have had a chance to cool down.

## 2. Unpacking & Assembly

1. Remove all components from the packaging and check for damage.
2. Place the frame on a level surface and slide both wheels onto the main frame axle (secure with the R clips included in the assembly kit.)
3. Remove the engine from its packing, attach the spacer key pulley and washers to the crankshaft and fix with the relevant bolt provided.
4. Remove the right hand section of the upper belt guard, a drive belt is pre-installed under this cover.
5. Assemble the engine by first insuring that the belt is fitted on the engine pulley. Fix the engine to the base plate using the 4mm x 6mm x 35mm nuts and bolts and washers provided.
6. Apply a small amount of grease around the thread

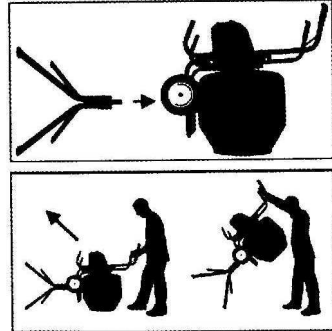

## 3. Operating Guidelines

Mixing Guidelines:

1. Start the mixer and ensure that the drum is rotating
2. Add water to prevent contents sticking to the drum.
3. Add the cement.
4. Add the aggregate



**Important:** After unpacking, inspect the equipment carefully and ensure that the product is in perfect condition without any defects or no damaged or worn parts. Please dispose of all the packaging materials appropriately, recycling all materials where facilities are available.

## 4. Specifications

### SPECIFICATIONS

Engine:	Macgen 2.4HP OHV Petrol
Starting System:	Recoil
Drum Capacity:	130L / 5ft³
Batch Output:	70L / 2.5ft³
Drum Diameter:	61cm
Drum Speed:	24rpm @ 2800rpm
Discharge Outlet Height:	104cm
Wheel Size:	25cm x 6.5cm
Operating Dimensions:	138cm x 110cm x 62cm
Storage Dimensions:	93cm x 66cm x 93cm
Weight:	75kg
Guaranteed Sound Power Level:	101db Lwa

## 5. Maintenance & Storage

### Before Each Use:

Inspect the power cable to ensure that it is completely free from damage and that all fittings are tight and secure.

### Periodically

Inject a few drops of light oil onto the moving parts (wheel axles, swivel brackets etc.)

### After each use

Hose down the drum and stand with clean water. Take care to prevent any water entering the motor housing and electrical components by protecting them with waterproof covering during the cleaning process.

### Storage

Store in a safe dry environment away from children and animals.

## 6. Parts List & Diagram

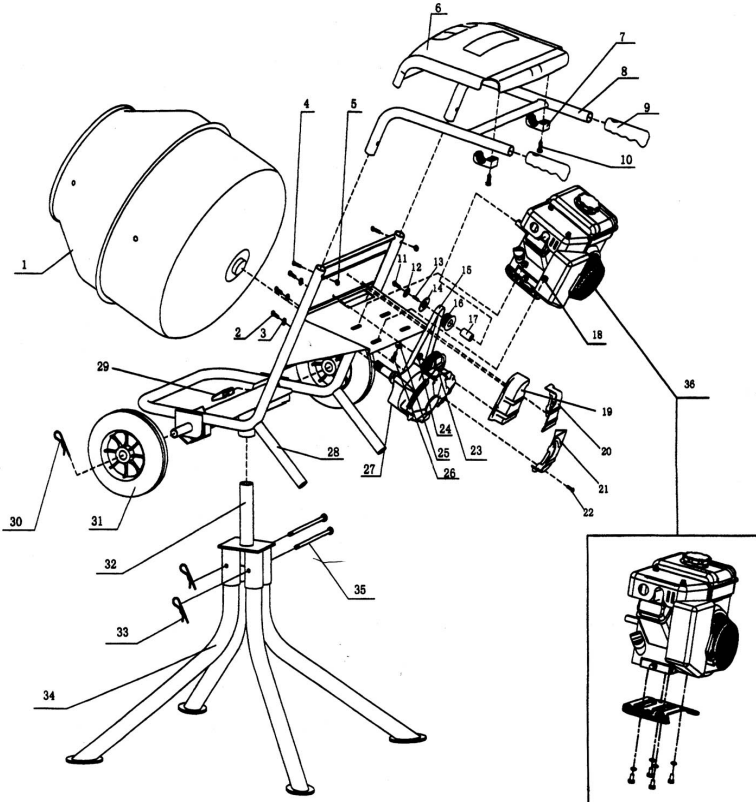

No.	Code	Qty	No.	Code	Qty	No.	Code	Qty	No.	Code	Qty
1	Drum	1	10	Screw	1	19	Strap Cover-L	1	28	Brackets	1
2	Bolt (M10 X 25)	4	11	Bolt (M6 X 25)	1	20	Strap Cover-R	1	29	Stop Bolt	1
3	Washer (10)	4	12	Washer	1	21	Strap Cover-U	1	30	Pin	2
4	Bolt (M8x40)	2	13	Key (5x18)	1	22	Screw (M5x10)	6	31	Wheel	2
5	Nut (M8)	2	14	Set Washer	1	23	Pulley	1	32	Shaft Housing	1
6	Engine Cover	1	15	Flat Toothed Belt	1	24	Spring Washer 13	1	33	Pin	2
7	Block	2	16	Driver	1	25	Washer (8)	4	34	Stand	4
8	Handle	1	17	Pipe Box	1	26	Bolt (M8 X 15)	8	35	Pin	2
9	Cover	2	18	Nut M8	4	27	Gear Box	1	36	Engine Assembly	1

## Limited Warranty Statement

Jefferson Professional Tools & Equipment, or hereafter "Jefferson" warrants its customers that its products will be free of defects in workmanship or material. Jefferson shall, upon suitable notification, correct any defects, by repair or replacement, of any parts or components of this product that are determined by Jefferson to be faulty or defective.

This warranty is void if the equipment has been subjected to improper installation, storage, alteration, abnormal operations, improper care, unauthorised service or repair.

### Warranty Period

Jefferson will assume both the parts and labour expense of correcting defects during the stated warranty periods below.

All warranty periods start from the date of purchase from an authorised Jefferson dealer. If proof of purchase is unavailable from the end user, then the date of purchase will be deemed to be 3 months after the initial sale to the distributor.

#### 1 Year

- All Jefferson Cement Mixers

#### 90 Days

- All replacement parts purchased outside of the warranty period

**Important:** All parts used in the repair or replacement of warranty covered equipment will be subject to a minimum of 90 days cover or the remaining duration of the warranty period from the original date of purchase.

### Warranty Registration / Activation

You can register and activate your warranty by visiting the Jefferson Tools website using the following address: [www.jeffersonstools.com/warranty](http://www.jeffersonstools.com/warranty) and completing the online form. Online warranty registration is recommended as it eliminates the need to provide proof of purchase should a warranty claim be necessary.

### Warranty Repair

Should Jefferson confirm the existence of any defect covered by this warranty the defect will be corrected by repair or replacement at an authorized Jefferson dealer or repair centre.

### Packaging & Freight Costs

The customer is responsible for the packaging of the equipment and making it ready for collection, **together with a proof of purchase**. Jefferson will arrange collection and transportation of any equipment returned under warranty. Upon inspection of the equipment, if no defect can be found or the equipment is not covered under the terms of the Jefferson warranty, the customer will be liable for any labour and return transportation costs incurred.

These costs will be agreed with the customer before the machine is returned.

\* Jefferson reserve the right to void any warranty for damages identified as being caused through misuse

## Warranty Limitations

Jefferson will not accept responsibility or liability for repairs made by unauthorised technicians or engineers. Jefferson's liability under this warranty will not exceed the cost of correcting the defect of the Jefferson products.

Jefferson will not be liable for incidental or consequential damages (such as loss of business or hire of substitute equipment etc.) caused by the defect or the time involved to correct the defect. This written warranty is the only express warranty provided by Jefferson with respect to its products.

Any warranties of merchantability are limited to the duration of this limited warranty for the equipment involved.

Jefferson is not responsible for cable wear due to flexing and abrasion. The end user is responsible for routine inspection of cables for possible wear and to correct any issues prior to cable failure.

**Important:** *Jefferson Tools will be unable to process any warranty coverage applications without a copy of the proof of purchase.*

## Claiming Warranty Coverage

The end user must contact Jefferson Professional Tools & Equipment (**Tel:** +44 (0) 1244 646 048) or their nearest authorised Jefferson dealer where final determination of the warranty coverage can be ascertained.

### Step 1 - Reporting the Defect

#### *Online Method:*

- Visit our website [www.jeffersonstools.com/warranty](http://www.jeffersonstools.com/warranty) and complete the Warranty Returns form. You can complete the form online and submit it to us directly or download the form to print out and return by post.

#### *Telephone Method:*

Contact your Jefferson dealer or sales representative with the following information:

- Model number
- Serial number (usually located on the specification plate)
- Date of purchase

A Warranty Returns form will be sent to you for completion and return by post or fax, together with details of your nearest authorised Jefferson repair centre. On receipt of this form Jefferson will arrange to collect the equipment from you at the earliest convenience.

### Step 2 - Returning the Equipment

It is the customer's responsibility to ensure that the equipment is appropriately and securely packaged for collection. Please ensure that you include a copy of your proof of purchase. Please note that Jefferson cannot assume any responsibility for any damage incurred to equipment during transit. Any claims against a third party courier will be dealt with under the terms & conditions of their road haulage association directives.

### Step 3 - Assessment and Repair

On receipt, the equipment will be assessed by an authorised Jefferson engineer and it will be determined if the equipment is defective and in need of repair and any repairs needed are covered by the warranty policy. In order to qualify for warranty cover all equipment presented must have been used, serviced and maintained as instructed in the user manual.

Where repair is not covered by the warranty a quotation for repair, labour costs and return delivery will be sent to the customer (normally within 7 working days).

**Note:** *If the repair quotation is not accepted Jefferson Professional Tools & Equipment will invoice 1 hour labour time at £30 per hour plus return carriage costs (plus VAT).*

*In cases where no fault can be found with the equipment, or, if incorrect operation of the equipment is identified as the cause of the problem, a minimum of 1 hour labour at £30 per hour plus carriage costs will be required before the equipment will be despatched back to the customer.*

*Any equipment repaired or replaced under warranty will normally be ready for shipment back to the customer within 7 working days upon receipt of the equipment at an authorised Jefferson Repair centre (subject to part availability). Where parts are not immediately available Jefferson will contact you with a revised date for completion of the repair.*

## General Warranty Enquiries

For any further information relating to Jefferson warranty cover please call **+44 (0) 1244 646 048** or send your enquiry via email to **warranty@jeffersonstools.com**.

# Jefferson®

## Parts & Servicing

For Jefferson approved replacement parts contact your nearest dealer or contact Jefferson tools

**Telephone:** +44 (0)1244 646 048  
**Fax:** +44 (0)1244 241 191  
**Email:** warranty@jeffersonstools.com

### **Disclaimer:**

*The information in this document is to the best of our knowledge true and accurate, but all recommendations or suggestions are made without guarantee. Since the conditions of use are beyond their control, Jefferson Tools® disclaim any liability for loss or damage suffered from the use of this data or suggestions. Furthermore, no liability is accepted if use of any product in accordance with this data or suggestions infringes any patent. Jefferson Tools® reserve the right to change product specifications and warranty statements without further notification. All images are for illustration purposes only.*

# EC Declaration of Conformity

We, Jefferson Professional Tools & Equipment, as the authorised European Community representative of the manufacturer, declare that the following equipment conforms to the requirements of the following Directives:

2000/14/EC (as amended)	<b>Noise Emission in the Environment by Equipment for Use Outdoors</b>
2004/108/EC (as amended)	<b>Electromagnetic Compatibility</b>
2006/42/EC (as amended)	<b>Machinery Directive</b>
97/68/EC (as amended)	<b>Non Road Mobile Machinery Directive</b>

**Equipment Category:** Petrol Concrete Mixer (Item 11)

**Product Name/Model:** JEFCEMPETBLK

The conformity assessment procedure followed was in accordance with Annex V of the Outdoor Noise Directive.

**Guaranteed Sound Power Level:** 101dB

**A copy of this certificate has been submitted to the European Commission and to the EU Member State, United Kingdom**

**Signed by:** Stephen McIntyre  
**Position in the company:** Operations Director  
**Date:** 09 January 2015



**This technical document is held by:** Jimmy Hemphill

*Technical file holder's address as shown below*

**Name and address of manufacturer or authorised representative:**



## **IMPORTANT! SAFETY FIRST!**

Before attempting to use this product please read all the safety precautions and operating instructions outlined in this manual to reduce the risk of fire, electric shock or personal injury.

Jefferson Tools, Herons Way, Chester Business Park, Chester, United Kingdom, CH4 9QR

**Tel.** +44 (0)1244 646 048

**Email:** [sales@jeffersonstools.com](mailto:sales@jeffersonstools.com)

**[www.jeffersonstools.com](http://www.jeffersonstools.com)**