

Kytun



Uni-Fix Contractor Dry Ridge Kit

Product Information

The KYTUN Uni-Fix Contractor Dry Ridge Kit provides a secure, easy fixed, waterproof finish for a wide range of concrete and clay ridge tiles protecting the ridge from wind uplift and rain.

The KYTUN Uni-Fix Contractor Dry Ridge Kit can be used with Universal Angle Ridges, Half Round and Plain Angled Ridge Tiles.

The KYTUN Uni-Fix Contractor Dry Ridge Kit should remain sealed in its box in a secure dry area until it is to be used. This will ensure no damage or loss of contents.



Uni-Fix Contractor Dry Ridge Kit



Kytun Uni-Fix Contractor Dry Ridge Kit

Contents

1 x 6m Ventilated Ridge Roll	13 x Dry Ridge Screws
13 x Dry Ridge Union Bracket	10 x Dry Ridge Batten Metal Strap
13 x Dry Ridge Clamping Plates	26 x Dry Ridge Clips

Material (See individual Material Safety Data Sheets)

Pitch Range: 15° – 60° Degrees.

The unique KYTUN Uni-Fix Dry Ridge Union bracket design allows for easy fixing to a wide range concrete & clay ridge tiles.

Installation

2.1 GUIDANCE NOTES

Every site and project will be different but in general there are a number of important principles for the roofer.

The KYTUN Uni-Fix Contractor Dry Ridge Union Bracket is a universal product which will work with a wide range of Concrete & Clay Ridge Tiles.

To ensure the product performs correctly over its lifetime it must be installed in the manner described below. NO deviation from the installation guide is recommended.

The general principles remain the same however and typical construction details are found in Section 2.2.

It is important when fixing the KYTUN Uni-Fix Contractor Dry Ridge Kit that the roof tiles lie on a level plane and be installed in accordance with the manufacturers guide. Please ensure you follow the installation information provided by the tile supplier to ensure the tiles are clipped or nailed correctly.

Uni-Fix Contractor Dry Ridge Kit

2.2 KYTUN UNI-FIX CONTRACTOR DRY RIDGE KIT INSTALLATION

1. Fix underlay and battens to the roof as normal apart from the top batten on each side. For the purposes of roof ventilation (where required), the roof underlay should stop short either side of the ridge by 25-30mm.
2. Depending on the type of Ridge tile (Universal Angle Ridges, Half Round and Plain Angled Ridge Tiles) there may need to be additional "ridge" battens secured onto the top of the ridge board. Place a Batten Strap on the top of the battens on the ridge board such that it can be bent downwards and onto the rafters either side. Fix the Batten Strap to the ridge battens and bend the Batten Strap down and on to the rafters either side and nail in place. One strap should be fixed in this way to each rafter along the whole length of the ridge. The remaining roof battens can now be fixed either side of the ridge.
3. At this stage the roof covering is finished to the ridge as per the manufacturer's instructions.

IMPORTANT: The top of the ridge-batten should be a maximum of 20mm from the underside of the Ridge Tile. This allows the fixing screw to get a strong fixing into the batten.

4. KYTUN Uni-Fix Ventilated Ridge Roll is then placed centrally along the ridge. Fix the Ventilated Ridge Roll at 300mm centres along its length. The two corrugated side strips are designed to drape down over the top row of tiles/slates on either side as the roll is opened out. The underside has a strip of self-adhesive butyl protected by an easy-release backing tape. Removing the backing tape the Ridge Roll is firmly applied by hand to the roof tiles. A ridge roll applicator is then used to securely fix in place.
5. Place the Kytun Dry Ridge Union Bracket onto the end of the ridge tile and insert 2no Dry Ridge Clips such that the Ridge Union Bracket is lifted and snug to the underside of the ridge tile - note the legs of the Dry Ridge Clips can be trimmed if the clip is pressing against the roof tiles / slates. Place the ridge tile over the ventilated ridge roll to ensure placement is correct.

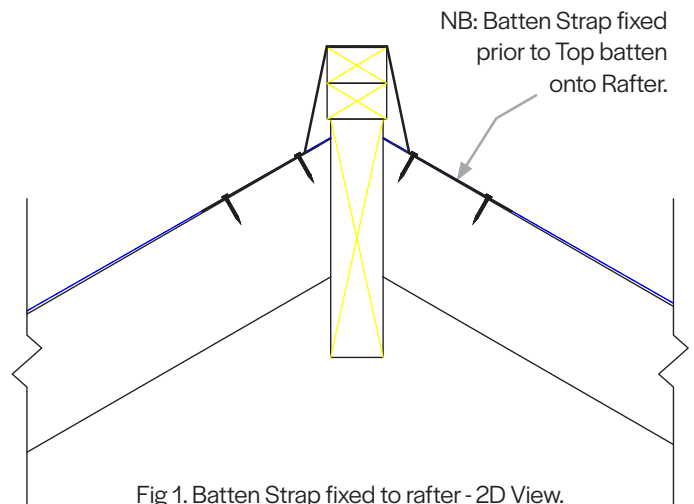

Fig 1. Batten Strap fixed to rafter - 2D View.

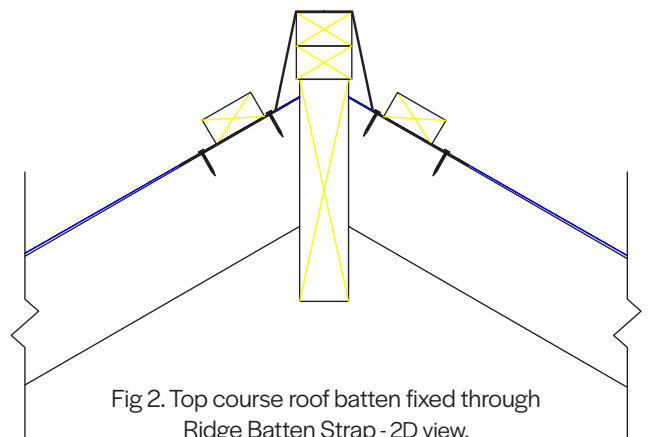

Fig 2. Top course roof batten fixed through Ridge Batten Strap - 2D view.

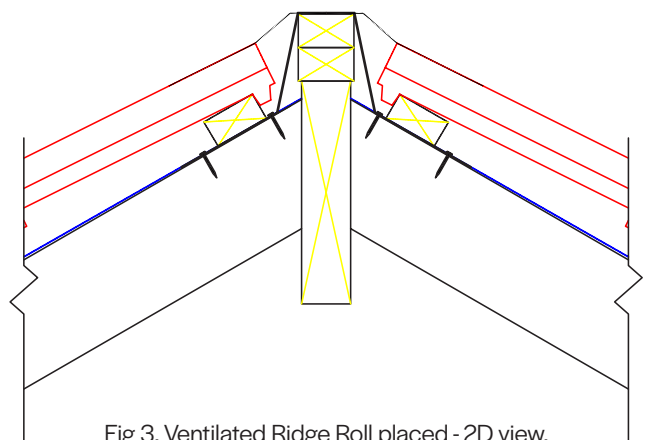

Fig 3. Ventilated Ridge Roll placed - 2D view.



Uni-Fix Contractor Dry Ridge Kit

6. Fix Ridge tiles using KYTUN Ridge Screws and Ridge Clamping Plates. (Fig.4)
7. This process is then repeated over the length of the ridge.
8. Where the ridge tiles run into a wall abutment or chimney stack the ridge tile should be secured as close to the lead flashing as possible by drilling the ridge tile as required and fixing using same process as above. Further information can be obtained by contacting the KYTUN technical department.

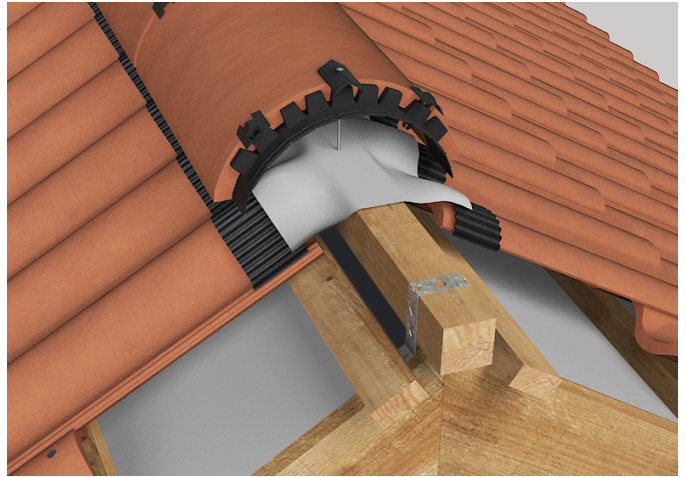

Fig 4. Fix ridge tile – 3D View.

Kytun

IRL (Head Office)
Keenaghan
Kilmacrenan
Letterkenny, Co. Donegal
F92 DW64
T: +353 (0) 74 91 39500
E: info@kytun.com

UK (Manufacturing Centre)
Senhouse Road
Darlington
Durham
DL1 4YB
T: +44 (0) 168 429 3702
E: info@kytun.com